

ALARMLINE II

Alarmline II Digital Linear Heat Sensor Cable Technical Manual

Content

	Important information	ii
Chapter 1	Introduction	1
	Overview	2
	Regulatory information	4
	Technical specifications	5
Chapter 2	Design and installation	9
	Design guidelines	10
	Installation	12
Chapter 3	Commissioning	19
	Passive checks	20
	Functional testing	20
Chapter 4	Application guidelines	23
	Overview	24
	Conveyor belts	25
	Escalators and moving walkways	27
	Cable trays and racks	28
	Floating roof storage tanks and bund areas	29
	Cold storage and freezer warehouses	31
	Index	33

Important information

Limitation of liability

To the maximum extent permitted by applicable law, in no event will UTCFS be liable for any lost profits or business opportunities, loss of use, business interruption, loss of data, or any other indirect, special, incidental, or consequential damages under any theory of liability, whether based in contract, tort, negligence, product liability, or otherwise. Because some jurisdictions do not allow the exclusion or limitation of liability for consequential or incidental damages the preceding limitation may not apply to you. In any event the total liability of UTCFS shall not exceed the purchase price of the product. The foregoing limitation will apply to the maximum extent permitted by applicable law, regardless of whether UTCFS has been advised of the possibility of such damages and regardless of whether any remedy fails of its essential purpose.

Installation in accordance with this manual, applicable codes, and the instructions of the authority having jurisdiction is mandatory.

While every precaution has been taken during the preparation of this manual to ensure the accuracy of its contents, UTCFS assumes no responsibility for errors or omissions.

Product warnings and disclaimers

THESE PRODUCTS ARE INTENDED FOR SALE TO AND INSTALLATION BY QUALIFIED PROFESSIONALS. UTC FIRE & SECURITY CANNOT PROVIDE ANY ASSURANCE THAT ANY PERSON OR ENTITY BUYING ITS PRODUCTS, INCLUDING ANY "AUTHORIZED DEALER" OR "AUTHORIZED RESELLER", IS PROPERLY TRAINED OR EXPERIENCED TO CORRECTLY INSTALL FIRE AND SECURITY RELATED PRODUCTS.

Advisory messages

Advisory messages alert you to conditions or practices that can cause unwanted results. The advisory messages used in this document are shown and described below.

WARNING: Warning messages advise you of hazards that could result in injury or loss of life. They tell you which actions to take or to avoid in order to prevent the injury or loss of life.

Caution: Caution messages advise you of possible equipment damage. They tell you which actions to take or to avoid in order to prevent the damage.

Note: Note messages advise you of the possible loss of time or effort. They describe how to avoid the loss. Notes are also used to point out important information that you should read.

Note: Kidde Products Ltd. has taken every care to ensure that Alarmline II Digital Linear Heat Detection systems are as simple to install as possible but in case of difficulty, please contact our Help Line to ensure trouble free installation and operation. Kidde Products Ltd. takes no responsibility for damage or injury occasioned as a result of failing to install or operate the equipment in accordance with these instructions.

Chapter 1

Introduction

Summary

This chapter provides an introduction to the product.

Content

Overview	2
Operation	2
Product range	3
Regulatory information	4
UL/ULC listings	4
FM approvals	5
Technical specifications	5

Overview

Alarmline II Digital Sensor Cables are a flexible durable and cost-effective form of fire detection, suitable for protecting a wide range of commercial and industrial applications.

They provide flexibility in installation enabling them to be used for general area protection or proximity detection close to a specific point of risk. A wide range of alarm temperatures, protective coatings, and installation fixings ensure system design and installation is specific to the risk. Alarmline II Digital Sensor Cables are especially suited for use in confined areas or areas with harsh environmental conditions where the use of other forms of detection is limited.

Alarmline II Digital Sensor Cables can be easily integrated to any fire control panel through a monitored input (a conventional detection zone, zone monitor unit, or switch monitor unit, etc.). The Digital Location Control Unit provides additional functionality to the Alarmline II Digital Sensor Cable system by being able to determine the alarm location along extended lengths of digital sensor cable (up to 3000 m).

This manual provides technical information, installation guidelines, and design recommendations for a selection of typical applications (it does not cover all possible applications – contact Kidde Products Ltd. technical support for further design and installation advice).

Operation

Alarmline II Digital Sensor Cables are constructed from a twisted pair of tri-metallic conductors covered with an advanced temperature-sensitive polymer. A protective outer coating is then extruded over the twisted pair.

Figure 1: Cable construction

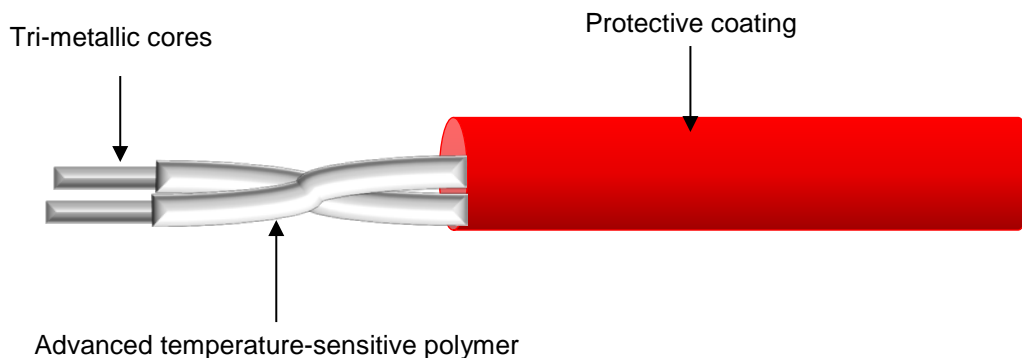

The two inner cores of the sensor cable are tightly twisted together to provide a mechanical tension between them. When the temperature-sensitive polymer reaches a specified temperature it begins to soften, the tension between the two inner cores forces the two conductors together creating a short circuit.

The simplistic operation of the Alarmline II Digital Sensor Cable makes it compatible with any control equipment capable of accepting contact closure type initiating devices.

Product range

The Alarmline II Digital Sensor Cable range consists of five fixed-temperature alarm cables, each with a range of protective coatings.

Table 1: Alarmline II Digital Sensor Cable product range

Part number	Description	Comments
AD68	Alarmline II Digital Sensor Cable – 68°C (155°F) PVC	Interior applications, general area coverage
AD68N	Alarmline II Digital Sensor Cable – 68°C (155°F) Nylon	Chemical/UV protection, exterior applications
AD68P	Alarmline II Digital Sensor Cable – 68°C (155°F) Polypropylene	Increased chemical protection in caustic environments
AD68SS	Alarmline II Digital Sensor Cable – 68°C (155°F) Stainless Steel over PVC	Increased mechanical protection
AD88	Alarmline II Digital Sensor Cable – 88°C (190°F) PVC	Interior applications, general area coverage
AD88N	Alarmline II Digital Sensor Cable – 88°C (190°F) Nylon	Chemical/UV protection, exterior applications
AD88P	Alarmline II Digital Sensor Cable – 88°C (190°F) Polypropylene	Increased chemical protection in caustic environments
AD88SS	Alarmline II Digital Sensor Cable – 88°C (190°F) Stainless Steel over PVC	Increased mechanical protection
AD105	Alarmline II Digital Sensor Cable – 105°C (221°F) PVC	Interior applications, general area coverage
AD105N	Alarmline II Digital Sensor Cable – 105°C (221°F) Nylon	Chemical/UV protection, exterior applications
AD105P	Alarmline II Digital Sensor Cable – 105°C (221°F) Polypropylene	Increased chemical protection in caustic environments
AD105SS	Alarmline II Digital Sensor Cable – 105°C (221°F) Stainless Steel over PVC	Increased mechanical protection
AD185N	Alarmline II Digital Sensor Cable – 185°C (365°F) Nylon	Chemical/UV protection, exterior applications
AD185SS	Alarmline II Digital Sensor Cable – 185°C (365°F) Stainless steel over Nylon	Chemical/UV and mechanical protection

Part number	Description	Comments
AD218	Alarmline II Digital Sensor Cable – 218°C (424°F) Silicone	Chemical/UV protection, exterior applications
AD218SS	Alarmline II Digital Sensor Cable – 218°C (424°F) Stainless steel over Silicone	Chemical/UV and mechanical protection

Additional coated cables are available for special applications:

- Polypropylene outer coating: Provides increased chemical protection within caustic environments.
- Stainless steel outer braid: Provides increased mechanical protection.

For further information regarding the specialist coatings, contact your local sales representative.

Regulatory information

UL/ULC listings

The sensor cables listed below have been tested and approved by UL and ULC to UTHV Heat actuated devices for special application and UQGS Heat-automatic fire detectors.

UL and ULC listed, file number S35630. Categories UTHV, UTHV7, UQGS, and UQGS7: "Heat activated devices for Special applications".

Table 2: UL/ULC listings

Cable	Alarm temperature	Outer coating	Spacing
AD68	68°C (155°F)	PVC	Maximum spacing 10.6 m (35 ft.) between sensor cable runs for general area coverage
AD68N	68°C (155°F)	Nylon	Maximum spacing 4.5 m (15 ft.) between sensor cable runs for general area coverage
AD88	88°C (191°F)	PVC	Maximum spacing 10.6 m (35 ft.) between sensor cable runs for general area coverage
AD88N	88°C (191°F)	Nylon	Maximum spacing 4.5 m (15 ft.) between sensor cable runs for general area coverage
AD105	105°C (221°F)	PVC	Maximum spacing 10.6 m (35 ft.) between sensor cable runs for general area coverage

Cable	Alarm temperature	Outer coating	Spacing
AD105N	105°C (221°F)	Nylon	Maximum spacing 4.5 m (15 ft.) between sensor cable runs for general area coverage
AD185N	185°C (365°F)	Nylon	Proximity detection only
AD218	218°C (424°F)	Silicone	Proximity detection only

FM approvals

The sensor cables listed below have been tested and approved by FM (Fire Detection, Heat Activated).

Table 3: FM approvals

Cable	Alarm temperature	Outer coating	Spacing
AD68	68°C (155°F)	PVC	Maximum spacing 9 m (30 ft.) between sensor cable runs for general area coverage
AD88	88°C (191°F)	PVC	Maximum spacing 9 m (30 ft.) between sensor cable runs for general area coverage
AD105	105°C (221°F)	PVC	Maximum spacing 7.6 m (25 ft.) between sensor cable runs for general area coverage
AD218	235°C (455°F)	Silicone	Proximity detection only

Technical specifications

Table 4: AD68 range

	AD68	AD68N	AD68P	AD68SS
Alarm temperature	68°C (155°F)			
Outer coating	PVC	Nylon	Polypropylene	Stainless steel over PVC
Outer colour	Red	Black	Red	Red
Outer diameter	3.6 mm (±0.12 mm) 0.142 in. (±0.005 in.)	4.44 mm (±0.12 mm) (0.175 in.) (±0.005 in.)	4.5 mm (±0.12 mm) (0.177 in.) (±0.005 in.)	4.1 mm (±0.12 mm) (0.161 in.) (±0.005 in.)
	2 × tri-metallic conductors Ø 0.912 mm (0.036 in.)			
Ambient temperature	45°C (113°F) max.			
Installation temperature	-10°C (14°F) min.			

	AD68	AD68N	AD68P	AD68SS
Operating temperature	-40°C (-40°F) min.			
Bend radius	50 mm (2 in.) min., extended to 100 mm (4 in.) for low temperature environments			
Voltage rating	30 VAC, 42 VDC max.			
Insulation rating	1 kV tested protective outer coat			
Resistance	90.5 Ω/km (27.6 Ω/1000 ft.) max. per conductor at 20°C			
Capacitance	<120 pF/m (<37 pF/ft.)			
Inductance	<1.6 μH/m (<0.49 μH/ft.)			

Table 5: AD88 range

	AD88	AD88N	AD88P	AD88SS
Alarm temperature	88°C (190°F)			
Outer coating	PVC	Nylon	Polypropylene	Stainless steel over PVC
Outer colour	White	Black	White	White
Outer diameter	3.6 mm (±0.12 mm) 0.142 in. (±0.005 in.)	4.44 mm (±0.12 mm) (0.175 in. (±0.005 in.)	4.5 mm (±0.12 mm) (0.177 in. (±0.005 in.)	4.1 mm (±0.12 mm) (0.161 in. (±0.005 in.)
	2 × tri-metallic conductors Ø 0.912 mm (0.036 in.)			
Ambient temperature	69°C (156°F) max.			
Installation temperature	-10°C (14°F) min.			
Operating temperature	-40°C (-40°F) min.			
Bend radius	50 mm (2 in.) min., extended to 100 mm (4 in.) for low temperature environments			
Voltage rating	30 VAC, 42 VDC max.			
Insulation rating	1 kV tested protective outer coat			
Resistance	89.5 Ω/km (27.3 Ω/1000 ft.) max. per conductor at 20°C			
Capacitance	<85 pF/m (<26 pF/ft.)			
Inductance	<1.72 μH/m (<0.52 μH/ft.)			

Table 6: AD105 range

	AD105	AD105N	AD105P	AD105SS
Alarm temperature	105°C (221°F)			
Outer coating	PVC	Nylon	Polypropylene	Stainless steel over PVC
Outer colour	White	Black	White	White
Outer diameter	3.6 mm (±0.12 mm) 0.142 in. (±0.005 in.)	4.44 mm (±0.12 mm) (0.175 in.) (±0.005 in.)	4.5 mm (±0.12 mm) (0.177 in.) (±0.005 in.)	4.1 mm (±0.12 mm) (0.161 in.) (±0.005 in.)
	2 × tri-metallic conductors Ø 0.912 mm (0.036 in.)			
Ambient temperature	69°C (156°F) max.			
Installation temperature	-10°C (14°F) min.			
Operating temperature	-40°C (-40°F) min.			
Bend radius	50 mm (2 in.) min., extended to 100 mm (4 in.) for low temperature environments			
Voltage rating	30 VAC, 42 VDC max.			
Insulation rating	1 kV tested protective outer coat			
Resistance	91 Ω/km (27.7 Ω/1000 ft.) max. per conductor at 20°C			
Capacitance	<73 pF/m (<22 pF/ft.)			
Inductance	<1.65 µH/m (<0.5 µH/ft.)			

Table 7: AD185 range

	AD185N	AD185SS
Alarm temperature	185°C (365°F)	
Outer coating	Nylon	Stainless steel over PVC
Outer colour	Red	White
Outer diameter	4.44 mm (±0.12 mm) (0.175 in. (±0.005 in.))	5 mm (±0.12 mm) (0.197 in. (±0.005 in.))
	2 × tri-metallic conductors Ø 0.912 mm (0.036 in.)	
Ambient temperature	125°C (257°F) max.	
Installation temperature	-10°C (14°F) min.	
Operating temperature	-40°C (-40°F) min.	
Bend radius	50 mm (2 in.) min., extended to 100 mm (4 in.) for low temperature environments	

	AD185N	AD185SS
Voltage rating	30 VAC, 42 VDC max.	
Insulation rating	1 kV tested protective outer coat	
Resistance	91 Ω /km (27.7 Ω /1000 ft.) max. per conductor at 20°C	
Capacitance	<90 pF/m (<27 pF/ft.)	
Inductance	<1.62 μ H/m (<0.49 μ H/ft.)	

Table 8: AD218 range

	AD218	AD218SS
Alarm temperature	UL/ULC approval at 218°C (424°F) FM approval at 235°C (455°F)	
Outer coating	Silicone rubber	Stainless steel over silicone
Outer colour	Green	Green
Outer diameter	5 mm (\pm 0.1 mm) (0.196 in. (\pm 0.004 in.))	5.5 mm (\pm 0.11 mm) (0.216 in. (\pm 0.04 in.))
	2 \times tri-metallic conductors \varnothing 0.912 mm (0.036 in.)	
Ambient temperature	170°C (338°F) max.	
Installation temperature	-10°C (14°F) min.	
Operating temperature	-40°C (-40°F) min.	
Bend radius	63.5 mm (2.5 in.) min., extended to 127 mm (5 in.) for low temperature environments	
Voltage rating	70 VAC, 100 VDC max.	
Insulation rating	5 kV tested protective outer coat	
Resistance	90 Ω /km (27.4 Ω /1000 ft.) max. per conductor at 20°C	
Capacitance	<85 pF/m (<26 pF/ft.)	
Inductance	<2.00 μ H/m (<0.61 μ H/ft.)	

Chapter 2

Design and installation

Summary

This chapter provides design guidelines and installation information for your product.

Content

Design guidelines	10
Proximity detection	10
Area coverage	11
Installation	12
Jointing	14
Connecting sensor cable to a monitored input	14
Interposing or leader cable	16
Digital Location Control Unit	16
Hazardous area installation	17

Design guidelines

The design and installation of an Alarmline II Digital Linear Heat Detection system is unique to every site and application, therefore it is recommended that this work is only undertaken by trained and competent persons following the guidelines in this chapter.

There are two main types of protection that can be provided by the Alarmline II Digital Sensor Cable:

Proximity detection: The sensor cable is installed close to the point of risk, generally around the equipment to be protected. There is no specific design criteria for these applications but there are guidelines to be considered.

Area coverage: The sensor cable is distributed throughout the risk area allowing protection of the general area as opposed to specific points. Alarmline II Digital Sensor Cable offers an alternative to point type heat detectors in this type of application.

Proximity detection

- Selection of the appropriate sensor cable type is critical to ensure correct performance of the system. The cable selection will be based on the maximum possible ambient temperature within the risk area and the required alarm temperature.
- The sensor cable should be installed close enough to the point of risk to give an acceptable response, but not in a position where it can be damaged or obstruct any moving parts. The location of the sensor cable should not restrict access to any parts of the equipment which require maintenance.
- The thermal path to the sensor cable should not be obstructed and a minimum distance of 25 mm should be left between the sensor cable and any surface it is being mounted to.
- In outdoor applications, shield the sensor cable from direct sunlight to control the ambient temperature around the cable and to prevent the risk of false alarms.
- In hazardous areas, galvanic isolators or intrinsically safe (IS) barriers are required to provide an IS circuit.
- Fixing of the cable will be determined by the application and the location at which the cable is installed. Support the cable to prevent sagging. The environmental conditions and clips to be used must be considered.

Area coverage

In applications where the sensor cable is installed for general area coverage (as an alternative to point type heat detectors), the positioning of the sensor cable typically follows the applicable local standards or approvals. The sensor cable is typically installed at ceiling height and laid out so that sufficient coverage is provided (see Figure 2 below).

Maximum spacing between cable runs typically follows the same limits as normal point type heat detectors and as defined by applicable local standards, as shown in the table below.

Table 9: Maximum spacing between cable runs

Standard	Maximum spacing
BS 5839	7.5 m (24.5 ft.)
UL/ULC	9 m (30 ft.)
FM	9 m (30 ft.)

Figure 2: Distributed sensor cable for general area coverage

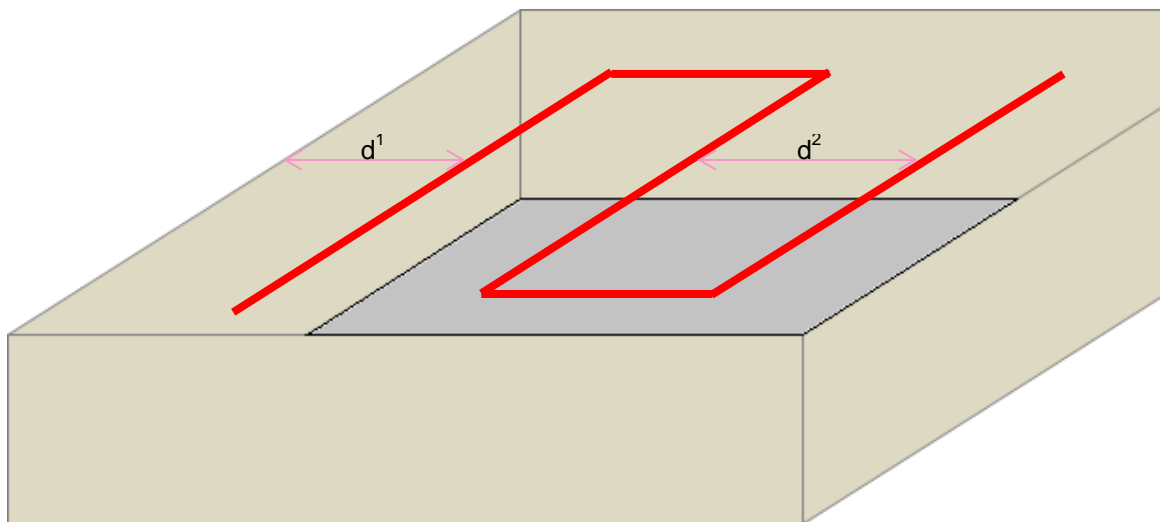

d^1 – Spacing of sensor cable from the wall ($d^1 = (d^2/2)$)
 d^2 – Spacing between sensor cable runs

Other design recommendations for general area coverage systems:

- Selection of the appropriate sensor cable type is critical to ensure correct performance. The selection of the cable will be based on the maximum possible ambient temperature within the risk area and the alarm temperature of the cable.
- The recommended total area coverage for a single Alarmline II Digital detection zone shall be no more than 2000 m² (21,528 ft²).

- The cable should be installed no closer than 25 mm and no further than 150 mm from the fixing surface.
- Fixing of the cable will be determined by the application and the installation location. The cable must be supported at 1 m intervals (min.), with additional supports where there are bends in the cable. The environmental conditions and clips to be used must be considered.
- The minimum bend radius when installing AD68, AD88, AD105, and AD185 sensor cables in ambient conditions of 0°C (32°F) and above is 50 mm (2 in.) or 63.5 mm (2.5 in.) for AD218 sensor cables.

For areas where ambient conditions are likely to be less than 0°C (32°F) the minimum bend radius for AD68, AD88, AD105, and AD185 sensor cables is 100 mm (4 in.) or 127 mm (5 in.) for AD218 sensor cables.

In hazardous areas, galvanic isolators or intrinsically safe (IS) barriers are required to provide an IS circuit.

Installation

Caution: This product must be installed and maintained by qualified personnel adhering to all local or national installation requirements and any other applicable regulations.

As well as the installation of the sensor cable within the risk area this section also provides details on interfacing the sensor cable into the fire alarm monitoring equipment.

Installation guidelines

Note: Perform a continuity test on the reeled cable prior to installation to ensure that no damage has occurred during transit.

It is not possible to provide definitive installation instructions as each application will be uniquely different. The following points outline general requirements for installation.

- Sensor cable must only be installed in the area to be protected. If the equipment monitoring the sensor cable is not installed within the risk area then a suitable interposing/leader cable can be connected between the sensor cable and the monitoring equipment.
- Sensor cables can be provided with various outer sheaths to suit the environment (PVC, nylon, polypropylene, and stainless steel braid). Be sure to select the correct protective outer sheath to suit the environment.
- Sensor cables should be terminated in junction boxes that are suitable to the environment.

- Sensor cable fixing clips should be suitable for the environment and the surface they are being fitted to. There is no requirement for the sensor cable to be tensioned, however on straight runs it is recommended to support the cable at a distance of 1 m to prevent sagging.
- When using metal fixing clips, protect the cable at the fixing points by using the silicone sleeve around the sensor cable.
- The minimum bend radius for AD68, AD88, AD105, and AD185 sensor cables is 50 mm (2 in.) or 63.5 mm (2.5 in.) for AD218 sensor cables.

For areas where ambient conditions are likely to be less than 0°C (32°F) the minimum bend radius for AD68, AD88, AD105, and AD185 sensor cables is 100 mm (4 in.) or 127 mm (5 in.) for AD218 sensor cables.

- Sensor cable is supplied on drums of 100 m, 500 m, and 1000 m and can be easily jointed to create the required sensor cable length.
- Do not paint the sensor cable.
- Where possible, fixing of the sensor cable should be the last stage in the installation to prevent any damage to the cable during other installation tasks.
- Pull the sensor cable from the reel using a reel stand. Do not pull the cable off the reel vertically as this may damage the cable.

Chemical resistance

Table 10: Chemical resistance comparison

	PVC coating	Nylon coating	Polypropylene coating	Silicone coating
Ammonia liquid	*****	***	*****	***
Butane	*****	*****	*	**
Copper nitrate	*****		*****	*****
Fuel oils	*****	*****	***	***
Gasoline	**	*****	**	***
Hydrofluoric acid	*	*	*****	*
Kerosene	*****	*****	*	***
Diesel fuel	*****	*****	*****	***
Acetic acid	**	*	*****	****

Jointing

One of the advantages of the Alarmline II Digital Sensor Cable is that damaged sections of cable can be cut out and replaced without having to replace the entire cable run. When a cable has been activated or has been damaged, the section of the cable can be cut away and a new section of cable can be jointed into the existing cable run.

Joint the cable using suitable junction boxes and ensure that it is jointed correctly to prevent any problems from bad connections, etc.

Connecting sensor cable to a monitored input

Caution: Before connecting the sensor cable to any control equipment, consult the technical documentation provided by the equipment manufacturer.

The sensor cable can be connected directly to any control equipment with a monitored input which can detect the operation of a switch changeover. The most common types of system would be either a conventional fire alarm control panel or an addressable fire alarm control panel.

For a conventional fire alarm panel, the sensor cable can be connected directly to a detection zone input. Any detection zone used would be specific to the Alarmline II Digital Sensor Cable with no other detection devices attached to the zone.

For an addressable fire alarm panel, the sensor cable can be connected to the control panel:

- Via the control panel monitored inputs (if available), or
- As a device on the addressable loop using a suitable loop interface (for example, a Zone Monitor Unit or Switch Monitor Unit)

Regardless of whether the sensor cable is fitted to a conventional detection zone or a loop interface on an addressable fire alarm control panel, the configuration is the same (see Figure 3 on page 15).

Figure 3: Connecting to a fire alarm control panel

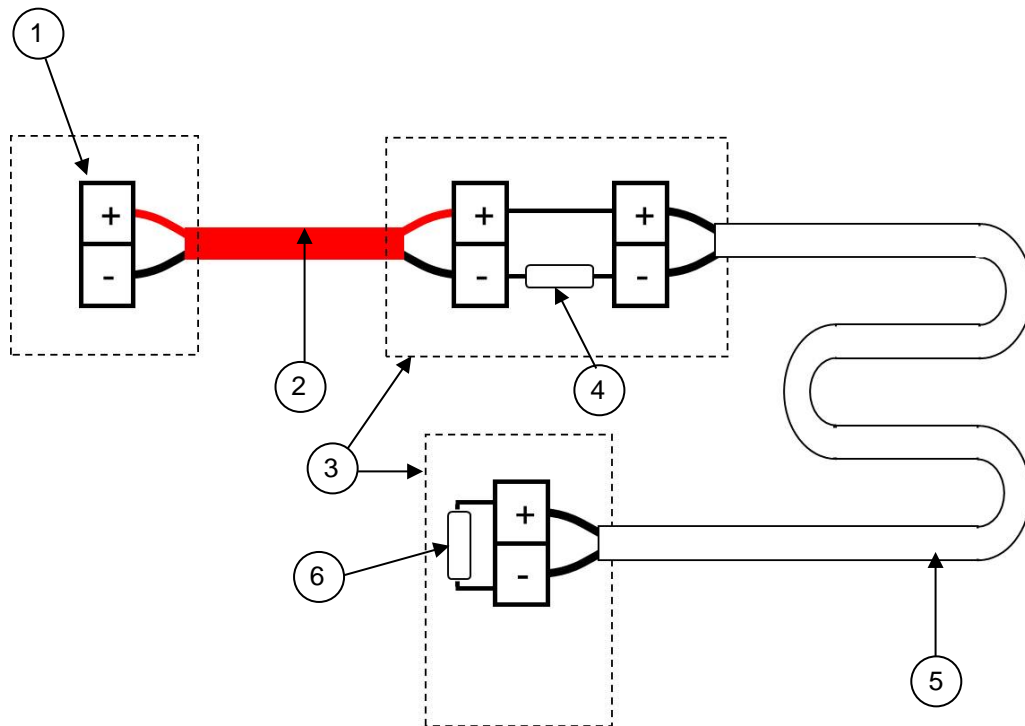

1. Connection terminals for monitored input (whether this is a conventional detection zone or a loop interface two terminals are provided). This input will monitor for changes in the resistance of the circuit to determine the presence of an open circuit or an alarm condition (short circuit).
2. Interposing or leader cable (the sensor cable must be installed only in the area that it is to protect). If the control equipment or interface is to be mounted remotely to the protected area, then a suitable two-core fire-rated cable can be used to make the connection between the two locations ("Interposing or leader cable" on page 16).
3. Suitable junction boxes should be used when terminating the sensor cable (for example, Ex junction boxes for hazardous areas). The diameter of the sensor cables range from 3.6 to 4.5 mm – be sure to select the correct size glands for junction boxes.
4. Alarm resistor. Monitored inputs will monitor for changes in the resistance of the circuit connected to it and different resistance values will indicate different events.

Conventional fire alarm panels and loop interfaces will have a specified alarm resistor value which must be fitted in series with the sensor cable for the system to activate an alarm condition. The alarm resistor value will vary dependent on the control equipment/interface and will be specified by the equipment manufacturer.

The position of the alarm resistor in the circuit is critical – it must be located at the start of the sensor cable. If using an interposing cable this allows the interposing cable to be monitored for open and short circuit faults only. Only when the sensor cable operates (short circuits) will the alarm resistor be introduced to the circuit activating an alarm at the control equipment.

5. The sensor cable must be installed only in the protected area and will be monitored for open circuit faults (short circuit on the sensor cable indicates an alarm). The correct temperature sensor cable must be selected for the application to prevent false alarms.
6. End-of-line monitoring device. This allows the control panel to monitor the integrity of the circuit completing the circuit and allowing sufficient current flow from the positive to negative terminals. The end-of-line monitoring device must be located at the end of the sensor cable and the value will be specified by the control equipment manufacturer. In the majority of cases the end-of-line devices will be supplied with the control panel.

Interposing or leader cable

The sensor cable must be installed only in the area that it is protecting. In some applications, you'll need to use an interposing or leader cable to connect the sensor cable to the monitoring equipment.

An approved fire-rated interposing or leader cable should be used and, when connecting the interposing or leader cable to the sensor cable, an IP66/67 rated junction box should be used. The maximum length of the interposing/leader cable will vary based on the cross-sectional area, as shown below.

The following maximum lengths of interposing or leader cable are based on the maximum length of sensor cable (3000 m or 9842 ft.).

Table 11: Maximum length of interposing or leader cable

Cable cross section	Maximum length
0.8 mm ² (18 AWG)	2,500 m (8,200 ft.)
1.3 mm ² (16 AWG)	3,500 m (11,500 ft.)
2.0 mm ² (14 AWG)	6,000 m (20,000 ft.)
3.3 mm ² (12 AWG)	9,500 m (31,000 ft.)

Digital Location Control Unit

For applications where long lengths of sensor cable are installed such as cable tunnels, road tunnels, and conveyor belts use a Digital Location Control Unit to detect the location of the alarm activation along a length of cable. A maximum of 3 km of Alarmline II Digital Sensor Cable can be attached to the Digital Location Control Unit.

Hazardous area installation

Note: When installing equipment in hazardous areas close liaison with the responsible site personnel is essential.

Alarmline II Digital Sensor Cable is classified as “simple apparatus” when it comes to Hazardous areas and does not require certification. The sensor cable can be installed within a hazardous area provided suitable safety barriers are used between the sensor cable and the control equipment.

The type of safety barrier shall be determined by the control equipment and therefore close liaison with the control equipment manufacturer is required to ensure the correct safety barrier is used. The safety barrier will be installed along with the control equipment in a safe area.

The relevant manufacturer’s documentation should be consulted for wiring details of barriers, configuration of monitoring equipment, etc.

To ensure that the system complies with hazardous area requirements, it is important to consider the electrical characteristics. Each safety barrier specifies the maximum resistance, capacitance, inductance, and L/R ratio of any device/cable that is attached to it (these details are provided in the specification tables in “Technical specifications” on page 5).

These characteristics may have a significant impact on the design of the system and may limit the length of sensor cable that can be used dependent on the safety barrier.

All terminations and connections on a hazardous area installation must be done in suitably approved junction boxes for the type of area.

Chapter 3

Commissioning

Summary

This chapter provides information on commissioning.

Content

Passive checks 20

Functional testing 20

Ensure that the installed sensor cable is fully tested and inspected prior to handover. Use the following guidelines to ensure that this is done correctly.

Passive checks

- Visually inspect the cable to ensure correct installation in accordance with the specification and system design.
- Check that the correct cable (alarm temperature) has been installed.
- Check each cable for mechanical damage, that all clips are securely held in place, and that the cable is correctly installed within the clips.
- Inspect all joints and terminations to ensure that they are correctly installed and appropriate for the application and environment.
- Ensure that the correct end-of-line device is fitted for the monitoring equipment used.
- Ensure that the correct value alarm resistor is installed and that it is in the correct location.
- Check that insulation resistance between conductors (excluding end-of-line devices) is 1000 M Ω per km (minimum).
- Check that the conductor resistance per km/ft. does not exceed that listed in “Technical specifications” on page 5.

Functional testing

Alarmline II Digital Sensor Cable is non-restorable and it is therefore not possible to test the cable by applying heat without damaging it. Simulated tests are recommended.

Simulated fault test

The sensor cable is monitored for open circuit fault only.

To perform the test:

1. To trigger a fault condition, remove any connection between the monitoring equipment and the sensor cable.
2. Confirm that the monitoring equipment registers a fault condition for the sensor cable.

Simulated alarm test

Testing of the cable will trigger an alarm at the monitoring equipment – isolate the monitoring equipment outputs as required.

To perform the test:

1. Ensure that the cable is connected to the monitoring equipment and that no faults are present.
2. Place a short circuit across the end of the sensor cable.
3. Hold the short circuit in place until the relevant alarm condition appears on the control panel.
4. Once the test has been completed, remove the short circuit and return all control units to normal status.

Functional alarm test

If required a functional alarm test can be performed by attaching a spare length of sensor cable to the end of the installed cable. This can then be heated to generate an alarm condition.

Testing of the cable will trigger an alarm at the monitoring equipment – isolate the monitoring equipment outputs as required.

To perform the test:

1. Fix a short length of cable (1 m, 3 ft.) between the end of the installed sensor cable and the end-of-line device.
2. Using a suitable heat source subject the cable to sufficient heat to reach the alarm temperature.
3. Confirm that the cable indicates the relevant alarm condition.
4. Remove the length of test cable and connect the end-of-line device to the sensor cable before resetting the monitoring equipment.

Chapter 4

Application guidelines

Summary

This chapter provides guidelines for typical applications.

Content

Overview 24

Conveyor belts 25

Escalators and moving walkways 27

Cable trays and racks 28

Floating roof storage tanks and bund areas 29

Cold storage and freezer warehouses 31

Overview

Alarmline Digital Sensor Cables have been successfully installed in a wide range of applications. Each application is different and a thorough risk assessment must be carried out to determine the best type of system and design. This section of the manual provides guidance on typical applications.

The following list includes applications where sensor cables have been used:

- Cable trays and risers
- Boilers
- Conveyors
- Transformers
- Control room and computer suites – floor voids
- Cooling towers
- Alternator pits
- Control cubicle protection
- Ducting and pipework
- Radar
- Missile storage
- Engine bay protection
- Chemical and fuel storage tanks – fixed roof
- Fuel storage tanks – floating roof
- Well heads
- Power units and pumps
- Cold-storage warehousing
- Service ducts
- Rolling stock
- Road and rail tunnels
- Dust extraction ducts
- Storage racking
- Grain silos and dryers
- Switchgear
- Cottages – thatched roof
- Paint spray booths
- Paint storage
- Reactor vessels
- Extraction and ventilation systems
- Wet bench applications
- Food processing and preparation areas
- Car parks
- Passenger walkways
- Distilleries
- Baggage conveyors
- Escalators
- Industrial kitchens – canopy protection

This list is for guidance only and other applications may exist which have not been included.

Conveyor belts

Conveyor belts are used on many sites to transport materials/product around the facility which can be anything ranging from coal, chemicals, luggage, minerals, or grain, etc.

The main causes of fires on conveyor belts are as follows:

- Friction (misaligned belts or seized rollers)
- Overheating (drive motors)
- Burning material (combustible material being carried on conveyor)

The effect of a fire on a conveyor can be significant as a moving conveyor could assist with the spread of fire over a larger area.

A number of important issues need to be considered when carrying out the risk assessment of the conveyor belt:

Table 12: Conveyor belt risk assessment

Assessment	Considerations
Location	If the conveyor belt is located outdoors and is not covered, then the detection system must be able to withstand being exposed to the elements without any effect on performance or causing false alarms.
Accessibility	If accessibility is likely to be an issue, then a system which requires little or no maintenance once installed is a significant advantage. Accessibility will become more of an issue on covered conveyors.
Key risk areas	Many of the key risk areas may be out of sight (roller bearings underneath the belt, drive motor, cabinets, etc.).
Fuel type	The type of material being carried on the conveyor – is it combustible, is there the potential for a dust explosion, etc. It may be necessary to provide a detection system which is suitable for hazardous areas. The fuel type would also help determine the requirement for any automatic fire-fighting equipment and which type.
Interaction	Should the detection system trigger an alarm, what actions are to be taken (automatic shutdowns, visual/audible warnings, activation of automatic firefighting equipment, etc.).

Alarmline II Digital Sensor Cable can provide a highly effective detection solution for the protection of conveyor belts. The flexibility of the sensor cable allows it to be installed very close to the point of risk (in close proximity to the belt and the rollers). Once installed the cable should require no maintenance unless it has been activated (and then only the damaged section of cable needs to be replaced). As it is a heat sensor, the cable is unaffected by the potential harsh environmental conditions providing the correct temperature cable is selected based on the maximum ambient.

Figure 4 on page 26 shows the recommended areas for installing Alarmline II Digital Sensor Cable on a conveyor belt.

Three locations are recommended for the sensor cable to provide complete detection on the conveyor belt.

Table 13: Recommended locations

Location	
Roller bearings	Problems with friction from a misaligned belt or a seized bearing will cause an overheat – by placing the sensor cable as close as possible to the roller bearings the earlier a potential incident can be detected. A controlled shutdown can be implemented preventing a potential fire incident. It is recommended that cable is run down both sides of the conveyor.
Above the belt	If the conveyor is covered it is recommended that sensor cable is fixed to the canopy above the conveyor belt to detect for any fires on the belt, enabling a controlled shutdown preventing potential fire spread by the moving escalator.
Underneath	It is a recommendation that sensor cable can also be installed underneath the conveyor to detect any fires that may occur due to trash or combustible fuel that may have fallen from the conveyor belt.

Figure 4: Sensor cable installation for covered conveyor

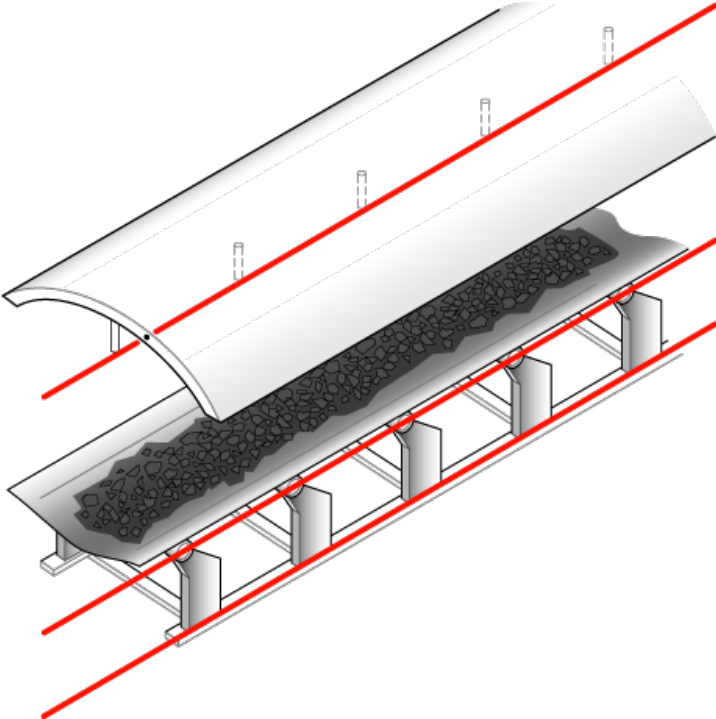

The sensor cable should be installed in such a way as to not interfere with maintenance and to prevent mechanical damage. Fixing clips should be selected based upon fixing location and available fixing surfaces (most commonly edge clips have been used to fit to the metal framework of the conveyor).

Escalators and moving walkways

Escalators and moving walkways can be found in many buildings such as shopping centres, airports, train stations, etc. Underneath the escalator there are many mechanical moving parts which can overheat due to friction if they become seized or damaged. Due to the confined space under the escalator and the harsh operating conditions (dust, oil, grease), it is a very difficult environment to install any fire detection equipment.

Alarmline II Digital Sensor Cable is flexible enough to be installed close to the main points of risk and be unaffected by the environment. Once the cable has been installed there is no need to access it for maintenance purposes.

Due to the number of moving parts within the escalator, it may be advantageous to use the stainless steel braided version of the cable which provides additional mechanical protection. The recommended clip type for this application is the edge clip (making installation easier and quicker).

There are three key areas of an escalator that should be considered when providing detection:

- Bearings
- Trash collector trays
- Drive motor housings

Sensor cable can be used to protect all of these areas.

Figure 5 below shows the principle of protecting an escalator or moving walkway with sensor cable. A continuous run of cable around the bearings and the trash collecting trays at either end provides significant coverage.

Figure 5: Sensor cable installation for escalators and moving walkways

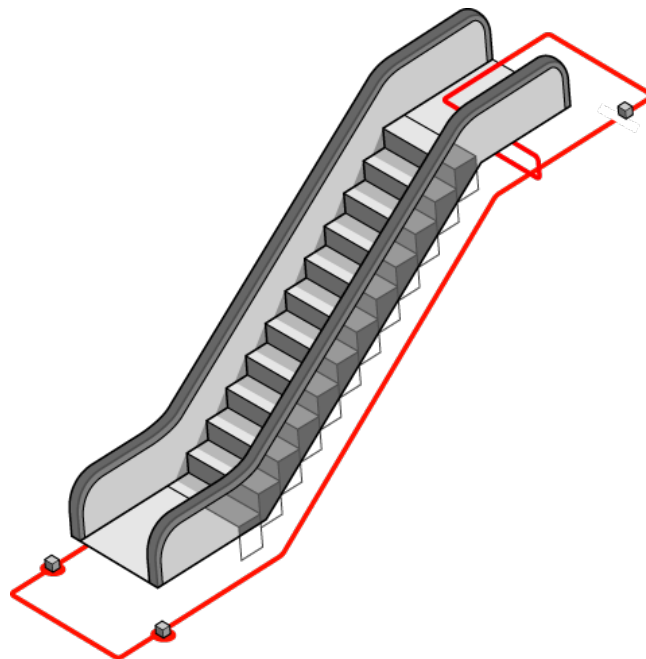

Cable trays and racks

In applications such as petrochemical plants, power generation plants, etc., miles and miles of cables are used transporting high voltages around the plant. These can be external cable trays exposed to the elements or can be underground cable trays hidden out of sight –either way overheating in a high voltage cable can cause significant damage. Alarmline II Digital Sensor Cable is a recognised solution for being able to protect these cables close to the point of risk.

As shown in Figure 6 on page 29, sensor cable is run above the cable tray to be able to detect an increase in temperature from the cables being protected. Generally one length of sensor cable is run down the cable tray but this may depend on the width of the cable tray. Where multiple cable trays exist it is recommended that sensor cable is run above each cable tray.

In power generation plants and large industrial installations the general principle of applying sensor cable to cable tray and racks follows the recommendations of the electricity generation companies in the United Kingdom.

- A single sensor cable can be used to protect cable trays up to 600 mm wide.
- Cable trays over 600 mm wide will require multiple runs of sensor cable to provide adequate coverage (cable trays up to 1200 mm wide require two sensor cable runs, cable trays up to 1800 mm wide would require three sensor cable runs, etc.)
- Sensor cable should be installed between 150 and 250 mm above the cable tray it's protecting.

The sensor cable is supported at 1 m spacing at a height of between 150 and 250 mm above each tray. This provides maximum operating sensitivity without obstructing access to power cables, etc. mounted on tray work. It is recommended to install sensor cable on the underside of the bottom tray or rack to further protect against "rubbish" fires.

Figure 6: Sensor cable installation for cable trays

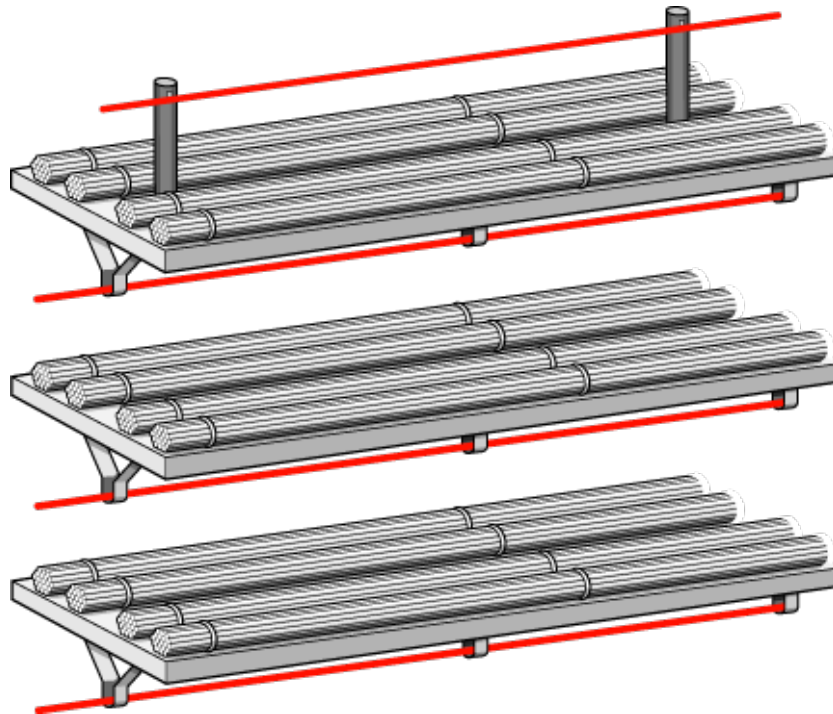

'V' clips are designed to support cables underneath layers of cable trays (this is a spring steel clip designed to fit the standard holes on a cable tray).

Floating roof storage tanks and bund areas

Floating roof storage tanks are a high risk application and liaison with experienced site personnel with regards to the design and installation requirements is essential.

Floating roof storage tanks are specifically designed for the safe storage of petroleum products such as crude oil or concentrates and the roof is designed to move up and down as the liquid content of the tank changes so there is no vapour space. A rim seal system is provided between the tank shell and the roof which prevents rim evaporation.

Alarmline II Digital Sensor Cable can be installed to detect an overheat condition or fire around the rim seal and can be used to provide a control signal to an automatic firefighting system (such as a foam system).

Sensor cable is installed close to the upper edge of the weather seal, using the roof's steel straps or the edge of the foam dam, where provided, as anchor points. Alternatively, support clips may be provided to suit. Sensor cable (or its interconnection wire) should be installed with consideration for the rise and fall of the floating roof, preferably using an approved retractable cable system (see Figure 8 on page 30).

Alarmline II Digital Sensor Cable is classified as a simple device and therefore requires no certification for use in hazardous areas, although suitable safety

barriers MUST be installed between the sensor cable and the control equipment located in a safe area of the site. The type of safety barrier will be determined by the monitoring equipment – this information should be readily available from the manufacturer of the monitoring equipment (see Figure 7 and Figure 8 below).

Figure 7: Sensor cable installation for floating roof tank

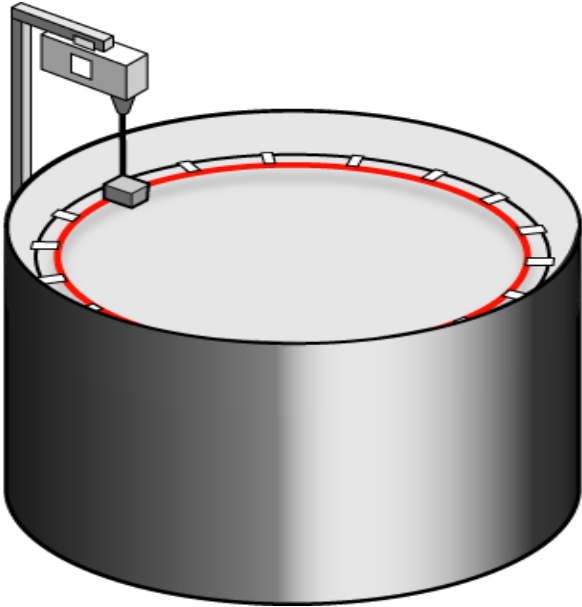
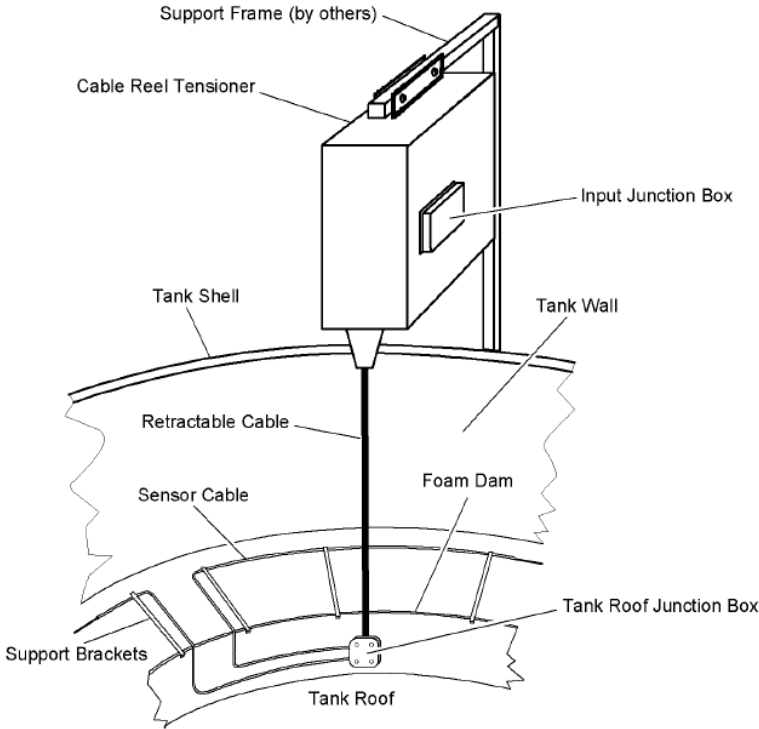

Figure 8: Detail of floating roof tank installation



Cold storage and freezer warehouses

Cold storage areas and freezer warehouses provide a difficult environment for many types of fire detection due to the sub-zero operating temperatures of such areas. With its minimum operating temperature of -40°C (-40°F) Alarmline II Digital Sensor Cable can provide an acceptable solution, allowing it to be installed in the risk area without being effected by the environment.

There are two ways the sensor cable can be used to provide fire detection in such an application:

- General area coverage, or
- In-rack detection

General area coverage follows the requirements detailed in “Area coverage” on page 11.

The alternative type of installation for these applications is storage rack detection. As with other applications, a significant advantage of using sensor cable is the flexibility to install it close to the point of risk. In storage areas by being able to install the cable within the storage racking itself it is closer to the risk and therefore able to detect an overheat or fire condition considerably quicker than general area heat sensors. This system also allows more accurate location of where the condition occurs.

Installation of the sensor cable can be done quickly and easily by using edge clips to fix the cable to the framework of the racking. Ensure that the cable is installed in a position where it is not likely to be damaged by loading and unloading of the storage racks.

The following precautionary measures must be considered when installing the sensor cable:

- Installation should not occur in temperatures lower than -11°C (12°F) as this can make the cable less flexible and more prone to damage. It may be necessary to raise the temperature of the area during installation and then return to the normal operating temperature after installation.
- Electronic interfaces and monitoring equipment must be installed outside the low temperature area – therefore interposing/leader cables and IP66/67 junction boxes will be required.
- The minimum bend radius at low temperatures is increased to 100 mm.

Index

A

- applications
 - cable trays and racks, 28
 - cold storage and freezer warehouses, 31
 - conveyer belts, 25
 - escalators and moving walkways, 27
 - floating roof storage tanks and bund areas, 29
- approvals
 - FM, 4
 - UL/ULC, 4

C

- chemical resistance, 13
- commissioning
 - functional alarm test, 21
 - passive checks, 20
 - simulated alarm test, 21
 - simulated fault test, 20

G

- guidelines
 - area coverage, 11
 - design, 10
 - installation, 12
 - proximity detection, 10
 - typical applications, 24

I

- installation
 - connecting to a monitored input, 14
 - hazardous area, 17
 - interposing or leader cable, 16
 - jointing, 14
 - maximum length of interposing or leader cable, 16
 - maximum spacing between cable runs, 11

R

- regulatory information, 4

S

- sensor cable
 - operation, 2
 - product range, 3

T

- technical specifications
 - AD105 range, 7
 - AD185 range, 7
 - AD218 range, 8
 - AD68 range, 5
 - AD88 range, 6
- testing
 - functional alarm test, 21
 - simulated alarm test, 21
 - simulated fault test, 20

